

**HOBART**

**PROLITE**  
GLASSWASHERS **GXB**



**HOBART**





## PROLITE

### TOTAL PERFORMANCE IN YOUR KITCHEN

At HOBART, we take pride in providing reliable and innovative high quality kitchen equipment that has been engineered to ensure that whatever challenges the day may bring - you can make it happen with HOBART. **Let's make it happen!**

#### PROLITE **GXCB**

The perfect solution for high washing volumes but low installation height under the counter. Rack size 500 x 500 mm, compact installation height of 705 mm.



#### PROLITE **GXB**

The large model for the bar, restaurant and hotel industry with high washing volumes. Rack size 500 x 500 mm, installation height 825 mm.



# BEST WASH RESULT

## GENIUS-X FINE FILTER SYSTEM

Best wash result and lower consumptions

The GENIUS-X fine filter system continuously puts the wash water through a system of strainers and filters during the washing process.

### Your benefits

- lower, constant water consumption
- precise dosing of the detergent and rinse aid as required
- reduced energy consumption
- no water exchange necessary

## THERMOSTOP FUNCTION

Hygienic wash result

Automatic cycle time control to achieve hygienic rinsing temperatures.

# EASY HANDLING

## ELECTRONIC CONTROL

Everything at a glance

With digital temperature indication and 3 programmes for easy operation.

## INTEGRATED WATER SOFTENER

Protects against calcification and increases service life

The water softening system, which can optionally be integrated, removes minerals from the water that can cause hardness. This prevents limescale deposits that lead to increased cycle times, burnt-out heating elements and unsatisfactory wash results.

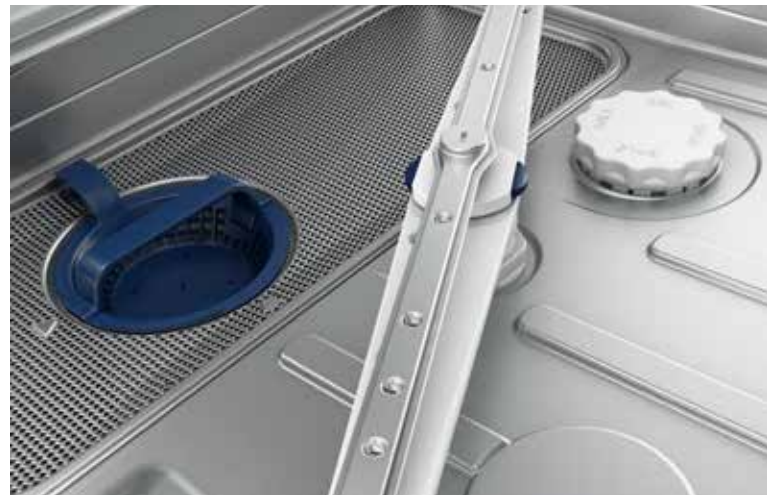

## CLIP-IN WASH- AND RINSE ARMS

Make cleaning the machine as simple as possible

To make your work as easy as possible, both wash and rinse arms can be removed using the CLIP-IN system in just one step. Following cleaning, all it takes is another click to put the washing attachment back in place.





## RELIABILITY & FLEXIBILITY

### SMOOTH COUNTERBALANCED DOOR

Soft, silent opening and closing

The glasswasher doors have gas-filled shock absorbers to protect your tableware and prevent wear of the door suspension.

**What's more:** The flat rack guides on the inside of the door make loading and unloading the rack easy.

### DOUBLE-WALLED HOUSING

Reduced noise and energy emission

The machine is double-walled, soundproof and heat-insulated.

### 705 MM INSTALLATION HEIGHT

Designed with every type of counter in mind

Compact and space-saving: The glasswasher GXCB fits under every type of counter with its installation height of only 705 mm.



# DRAWINGS

## GXCB

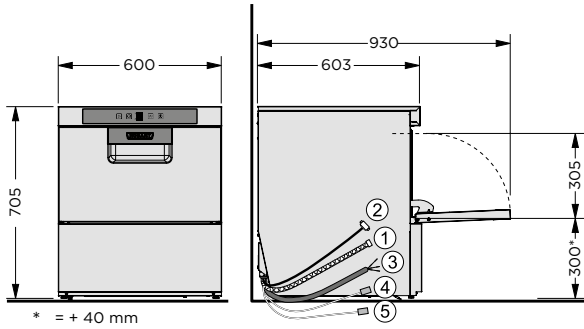

## GXB

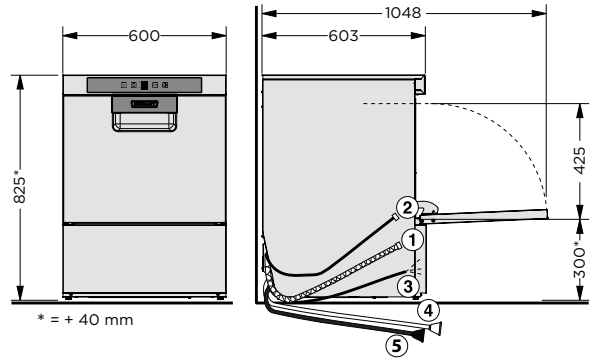

- [1] Drain hose
  - [2] Fresh water connection
  - [3] Connection cable
  - [4] Liquid detergent
  - [5] Rinse aid<sup>a)</sup>
- <sup>a)</sup> for machines with hose filling

# FEATURES

MODELS	GXCB	GXB
<b>BEST WASH RESULT</b>		
GENIUS-X fine filter system	●	●
Thermostop function	●	●
Tank cover strainer	●	●
Free-standing reverse osmosis RO-S	○	○
<b>EASY HANDLING</b>		
Electronic control	●	●
Refill signal	○	○
Self-cleaning programme	●	●
EASY-CLEAN concept	●	●
CLIP-IN wash and rinse arms	●	●
Integrated water softener	○	○
Integrated rinse pump	●	●
Integrated drain pump	●	●
Integrated detergent and rinse aid dosing	●	●
Integrated chemical containers with fill level indication	○	○
2 suction lances with fill level indication for external detergent and rinse aid containers	○	○
<b>RELIABILITY &amp; FLEXIBILITY</b>		
Smooth counterbalanced door	●	●
Multi-phasing (230/400 V)	●	●
Double-walled housing	●	●

● Inclusive      ○ Optional      – Not available

## TECHNICAL DATA

MODELS	GXCB	GXB
<b>CYCLE TIMES</b>	60 / 90 / 120 sec. and self-cleaning programme	60 / 90 / 120 sec. and self-cleaning programme
<b>CONNECTED LOAD</b>		
Racks	60 /h	60 /h
Glasses	2,160 /h	2,160 /h
<b>TANK CAPACITY</b>	10.6 l	10.6 l
<b>WATER CONSUMPTION</b>	2.0 l /rack	2.0 l /rack
<b>WASH PUMP</b>	0.5 kW	0.5 kW
Tank heating	1.7 kW	1.7 kW
<b>BOOSTER LOADING</b>		
Standard	6.2 kW	6.2 kW
Alternative	2.1 kW	2.1 kW
<b>TOTAL LOADING</b>		
Standard	6.8 kW   3 x 16 A	6.8 kW   3 x 16 A
Alternative	2.7 kW   16 A	2.7 kW   16 A
Power supply	400 / 50 / 3N (230 / 50 / 1)	400 / 50 / 3N (230 / 50 / 1)
<b>DIMENSIONS</b>		
Width	600 mm	600 mm
Depth	603 mm	603 mm
Height	705 mm	825 mm
Loading height	305 mm	425 mm
Rack size	500 x 500 mm	500 x 500 mm

## CONCEPT SOLUTIONS for optimised wash results

### WATER TREATMENT

The right solution for every water quality: Water softening plant to prevent the build-up of limescale and osmosis plant for a stainless wash result.

### WASHING CHEMICALS

The right detergent for every application – perfectly suited to the individual machine. The HYLINE hygienic range.



# HOBART

## DEUTSCHLAND/ÖSTERREICH

### HOBART GMBH

Robert-Bosch-Straße 17 | 77656 Offenburg  
Tel.: +49 781 600-0 | [info@hobart.de](mailto:info@hobart.de)  
[www.hobart.de](http://www.hobart.de)



Werkskundendienst +49 180 345 6258  
für Österreich +43 820 240 599

Zentraler Verkauf +49 180 300 0068

## NEDERLAND

### HOBART NEDERLAND B.V.

Pompmolenlaan 12 | 3447GK Woerden  
Tel.: +31 348 46 26 26  
[info@hobart.nl](mailto:info@hobart.nl)  
[www.hobart.nl](http://www.hobart.nl)

## KOREA

### HOBART KOREA LLC

7th Floor | Woonsan Bldg | 108 | Bangi-dong  
Songpa-gu | Seoul 138-050  
Phone: +82 2 34 43 69 01  
[contact@hobart.co.kr](mailto:contact@hobart.co.kr)  
[www.hobart.co.kr](http://www.hobart.co.kr)

## SCHWEIZ

### GEHRIG GROUP AG

Bäulerwisenstrasse 1 | 8152 Glattbrugg  
Tel.: +41 43 211 56-56  
[info@gehriggroup.ch](mailto:info@gehriggroup.ch)  
[www.gehriggroup.ch](http://www.gehriggroup.ch)

## NORGE

### HOBART NORGE

Gamle Drammensvei 120 A | 1363 HØVIK  
Tel.: +47 67 10 98 00  
[post@hobart.no](mailto:post@hobart.no)  
[www.hobart.no](http://www.hobart.no)

## JAPAN

### HOBART (JAPAN) K.K.

Suzunaka Building Omori  
6-16-16 Minami-Oi | Shinagawa-ku | Tokyo 140-0013  
Phone: +81 3 5767 8670  
[info@hobart.co.jp](mailto:info@hobart.co.jp)  
[www.hobart.co.jp](http://www.hobart.co.jp)

## FRANCE

### COMPAGNIE HOBART

ZI PARIS EST - Allée du 1er Mai - B.P. 68  
77312 MARNE LA VALLEE Cedex 2  
Téléphone: +33 1 64 11 60 00  
[contact@hobart.fr](mailto:contact@hobart.fr)  
[www.hobart.fr](http://www.hobart.fr)

## SVERIGE

### HOBART SCANDINAVIA APS

Varuvägen 9 | 125 30 Älvsjö  
Tel.: +46 8 584 50 920  
[info@hobart.se](mailto:info@hobart.se)  
[www.hobart.se](http://www.hobart.se)

## SINGAPORE

### HOBART INTERNATIONAL (S) PTE LTD

158 | Kallang Way | #06-03/05  
Singapore 349245  
Phone: +65 6846 7117  
[enquiry@hobart.com.sg](mailto:enquiry@hobart.com.sg)  
[www.hobart.com.sg](http://www.hobart.com.sg)

## UNITED KINGDOM

### HOBART UK

Southgate Way | Orton Southgate  
Peterborough | PE2 6GN  
Phone: +44 844 888 7777  
[customer.support@hobartuk.com](mailto:customer.support@hobartuk.com)  
[www.hobartuk.com](http://www.hobartuk.com)

## DANMARK

### HOBART SCANDINAVIA APS

Håndværkerbyen 27 | 2670 Greve  
Tel.: +45 43 90 50 12  
[salg@hobart.dk](mailto:salg@hobart.dk)  
[www.hobart.dk](http://www.hobart.dk)

## THAILAND

### HOBART (THAILAND)

43 Thai CC Tower Building | 31st FL  
Room No. 310-311 | South Sathorn Rd.  
Yannawa | Sathorn | Bangkok | 10120  
Phone: +66 2 675 6279 81 | [enquiry@hobartthailand.com](mailto:enquiry@hobartthailand.com)  
[www.hobartthailand.com](http://www.hobartthailand.com)

## BELGIUM

### HOBART FOSTER BELGIUM

Industriestraat 6 | 1910 Kampenhout  
Phone: +32 16 60 60 40  
[sales@hobart.be](mailto:sales@hobart.be)  
[www.hobart.be](http://www.hobart.be)

## AUSTRALIA

### HOBART FOOD EQUIPMENT

Unit 1/2 Picken Street | Silverwater NSW | 2128  
Tel.: +61 2 9714 0200  
[www.hobartfood.com.au](http://www.hobartfood.com.au)

## OTHER COUNTRIES

### HOBART GMBH

Robert-Bosch-Straße 17 | 77656 Offenburg | Germany  
Phone: +49 781 600-2820  
[info-export@hobart.de](mailto:info-export@hobart.de)  
[www.hobart-export.com](http://www.hobart-export.com)

Die Angaben in diesem Prospekt beruhen auf dem Stand 02/2022. Technische Änderungen oder Änderungen der Ausführung bleiben vorbehalten.

The details given in this brochure are correct as of 02/2022. We reserve the right to technical or design modifications.

Document non contractuel. Les indications de ce prospectus sont conformes à la mise à jour de 02/2022. Nous nous réservons le droit de modifier les données ou les configurations techniques de nos machines.

